

Specifications and Dimensions

GATEWAY 1700

	A	B	C	D	E	F
US	9"	12"	12"	12 1/2"	21"	20 3/4"
Canada	9"	12"	12"	12 1/2"	21"	20 3/4"

GATEWAY 2300

	A	B	C	D	E	F
US	7"	16"	7"	10 1/4"	25 1/4"	16 1/2"
Canada	7"	17"	7"	10 1/4"	26 1/4"	16 1/2"

GATEWAY 3500

	A	B	C	D	E	F
US	7"	14"	7"	11 3/4"	24 7/8"	17 3/4"
Canada	7"	14"	7"	11 3/4"	24 7/8"	17 3/4"

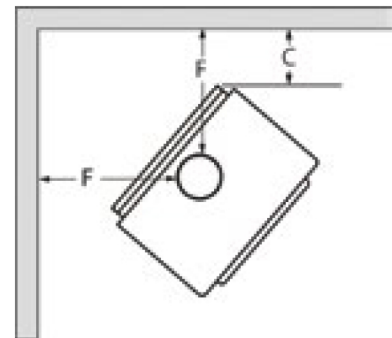
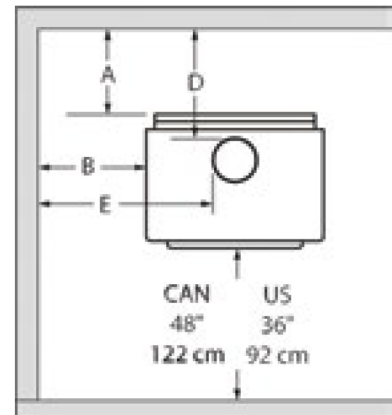

WARRANTY

LIMITED LIFETIME: Combustion chamber (welds only) and cast iron door frame, Ceramic Glass, Plating (manufacture defect), step top. **LIMITED 7 YEAR:** Surrounds, heat shields, ash drawer, pedestal, C-Cast Baffle, secondary air tubes, deflectors and supports. **LIMITED 5 YEAR:** Handle assembly, glass retainers, air control mechanism, removable carbon steel combustion chamber components. **LIMITED 2 YEAR:** Standard and optional blower, heat sensors, switches, rheostat, wiring and electronics. **LIMITED 1 YEAR:** Paint peeling, gaskets, insulation, ceramic fiber blankets, firebricks and other options. **LIMITED 90 DAY:** All parts replaced under warranty.

Empire is committed to continuous product improvement; specifications are subject to change without notice. Dimensions in this brochure are approximate; read and follow the clearances listed in the owners manual supplied with your Empire product. Flame size, shape, and color will vary from photos.

